

VITAFLOW, LLC

VF # 926-2½" Stripping Eductor

2" x 2½" x 2½"

VITAFLOW

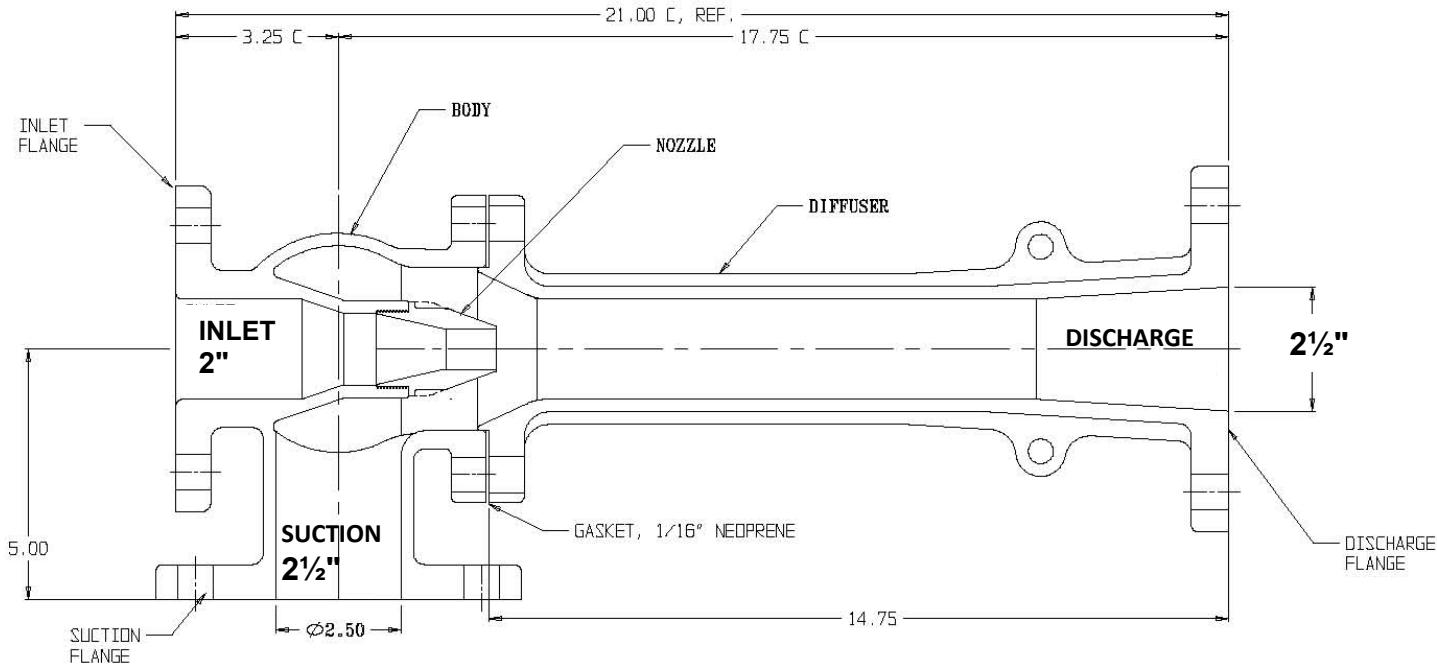

Flange Data : PER ANSI B16.24

150 LB CLASS

	INLET	SUCTION & DISCH.
ID	2"	2½"
OD	6"	7"
B.C.	4¾"	5½"
# Holes	4	4
Hole Ø	¾"	¾"



General Operating Conditions

- **Motive Pressure** Up to 175 PSI
- **Motive Flow** Up to 250 GPM
- **Suction Lift** Up to -23 Feet
- **Discharge Head** Up to 80 Feet
- **Suction Capacity** Up to 195 GPM

926-2½" Bill of Materials

Part #	Part Name	Qty	Material
92-6-A	Body	1	BRONZE ASTM B62
92-6-B	Diffuser	1	BRONZE ASTM B62
92-6-C	Nozzle	1	MONEL
92-6-D	Bolts	6	316 Stainless Steel
92-6-E	Nut	6	316 Stainless Steel
92-6-F	Lockwasher	6	316 Stainless Steel
92-6-G	Gasket	1	Garlock Gylon 3510

UNLESS OTHERWISE SPECIFIED
 1. REMOVE ALL BURRS, BREAK ALL OUTSIDE CORNERS
 EDGES .005 TO .010 X 45 DEG. CHAMFER
 2. STANDARD TOLERANCE .XX = ± .01 .XX C = ± .06
 .XXX = ± .005 .XXXX = ± .0005 FRACTIONS = ± .01
 CONCENTRICITY = ± .005 ANGULAR = ± .5 DEG

MATERIAL :
BRONZE

TITLE: 926-2 1/2 EDUCTOR ASSY., 2 1/2" SUCTION		VITA-MOTIVATOR CO., INC. TEANECK, N.J.
CAD ID: 92625 1016C		DO NOT SCALE DRAWING
DRWN BY JOP	DATE 8/12/09	PART NO.
CHKD BY	DATE	DRAWING NO. [926-2 1/2]
APPD BY	DATE	REV C
SCALE HALF	SHEET 1 OF 2	