

VM TYGER-ATX-2½" Multi-Jet Eductor Kit

The VM TYGER-ATX Portable Multi-Jet is used on board tankers, oil rigs and vessels of all types. The eductor is fitted with a multi-jet nozzle, which provides a straight through unrestricted suction path for superior no clog flow of liquid and solid mixtures. The TYGER ATX is excellent for cleaning sludge, muck, sand, grain, cement and coal.

The TYGER-ATX Eductor is used to remove slurries from tanks, sumps, pits, cargo and ballast spaces. This small and lightweight ejector allows access to inaccessible spaces for removal of many solids and liquid mixtures.

TYGER-ATX Portable Eductor Kit – includes:

- 1 pc VM # 92N-2½"L Bronze or Aluminum Eductor with Monel Nozzle
- 1 pc INLET HOSE – Fire “Motive Pressure” Hose, 75' (23M) x 1½" with brass (NPT) couplings for eductor inlet
- 1 pc SUCTION HOSE - Non-Collapsible PVC Full Vac. Hose, 20' (6 M) x 1½" with brass coupling for eductor suction
- 1 pc DISCHARGE HOSE – PVC (or) Heavy Duty EPDM Rubber Water Discharge Hose 75' (23 M) x 2½" with Brass coupling to eductor discharge.
- 1 ea. Suction Check Valve
- 1 ea. Spare Nozzle
- 1 ea. On – Off Ball Valve for shut off

Put a "Tyger" in your Tanker

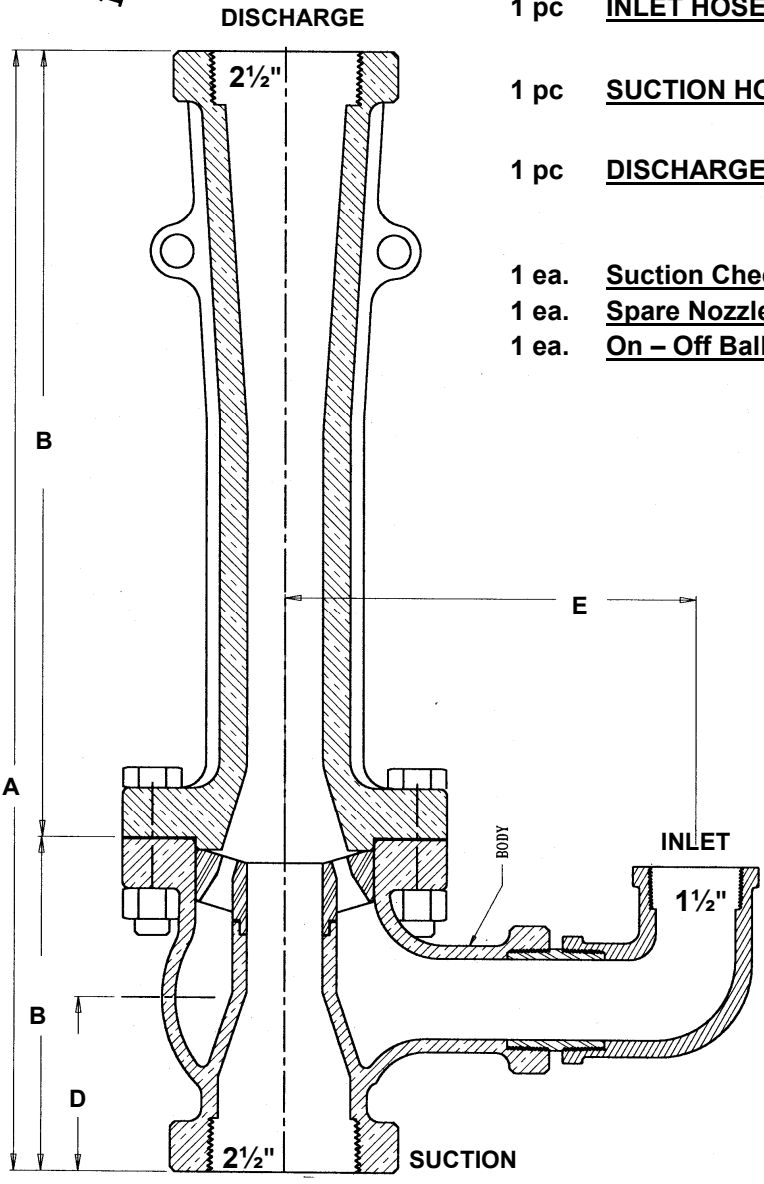

- ### SUGGESTED USES
1. Keeping tank bottoms dry during tank or hold washing operations
 2. **Will handle slurries and solids in suspension**
 3. Pumping water out of holds during firefighting operations
 4. Regular or emergency pumping of liquids from ballast, bilge or cargo spaces
 5. Powered by water pressure or the same liquid as suction fluid
 6. This model can be lowered directly into the liquid to be suctioned.
 7. Up to 20' of suction hose can be attached.

<u>Flow Data</u>	<u>Suction Capacity</u>	<u>Suction Lift</u>	<u>Discharge Head</u>	<u>Motive Pressure</u>	<u>Motive Flow</u>					
	Up to 154 GPM Up to 35 M3/H	Up to -20 Feet Up to -6 Meters	Up to 80 Feet Up to 25 Meters	50 -150 PSI 3 – 10 Bar	150 – 225 GPM 34 – 51 M3/H					
<u>Materials of Construction</u>	<u>Item</u>	<u>Standard Eductor</u>	<u>Optional Materials</u>							
	BODY & Diffuser	Aluminum	Bronze							
	Nozzle	Monel	316 Stainless Steel,							
	Throat Wear Lining	316 Stainless Steel	Monel							
<u>Dimensions</u>	<u>Inlet</u>	<u>1½"</u>	<u>(40)</u>	<u>A</u>	<u>B</u>	<u>C</u>	<u>D</u>	<u>E</u>	<u>I</u>	<u>WT</u>
	<u>Suction</u>	2½"	(65)	21"	6¼"	14¾"	3¼"	7¾"	1½"	20 #
	<u>Discharge</u>	2½"	(65)	533	159	374	82	197	38	9 kg